

## Table of contents

Monowall installation manual

<b>1.</b>	<b>Direction of installation</b>	<b>01</b>
<b>2.</b>	<b>Installation</b>	<b>01</b>
2.1	Horizontal installation	01
2.2	Vertical installation	01
<b>3.</b>	<b>Fixing</b>	<b>01</b>
<b>4.</b>	<b>Fixing material</b>	<b>02</b>
4.1	Fixing onto steel support structure	02
4.2	Fixing onto wooden support structure	02
<b>5.</b>	<b>Distance between fasteners</b>	<b>02</b>
5.1	Distances perpendicular towards clamping direction	02
5.2	Distances parallel towards clamping direction	02
<b>6.</b>	<b>Connections</b>	<b>02</b>
6.1	General notes	02
6.2	Upper connections	02
6.3	Roof parapet	02
6.4	Lower connections (base)	02
6.5	Small openings	02
6.6	External corner flashings	03
6.7	Longitudinal joint	03
6.8	Lateral joint	03



## Sandwich panel wall

### Monowall installation manual

### 1. Direction of installation

Monowall wall panels can be installed either vertically or horizontally. The panels are to be installed and fixed by placing them on support profiles at the base. For horizontal installation the vertical joints need to be sealed properly and covered by pilaster strips or other suitable flashings.

### 2. Installation

The first panel needs to be aligned perfectly and fixed immediately. The given building width of the panel needs to be maintained thoroughly; check measurements need to be performed every few panels. We recommend the use of Metecno-pressing tools for the installation of wall panels.

### Installation manual for download



SCAN ME

Connections to adjacent structures must be performed in professional and thorough manner.

#### 2.1 Horizontal installation

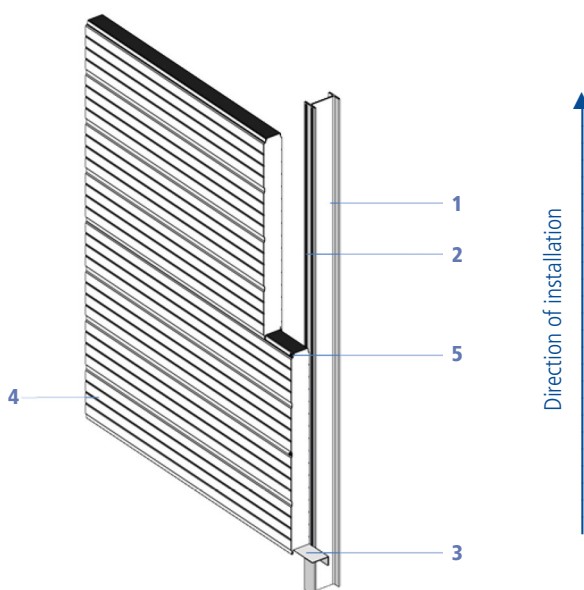

1. support structure, 2. sealing tapes, 3. supporting profile, 4. sandwich panel Monowall, 5. fastener

#### 2.2 Vertical installation

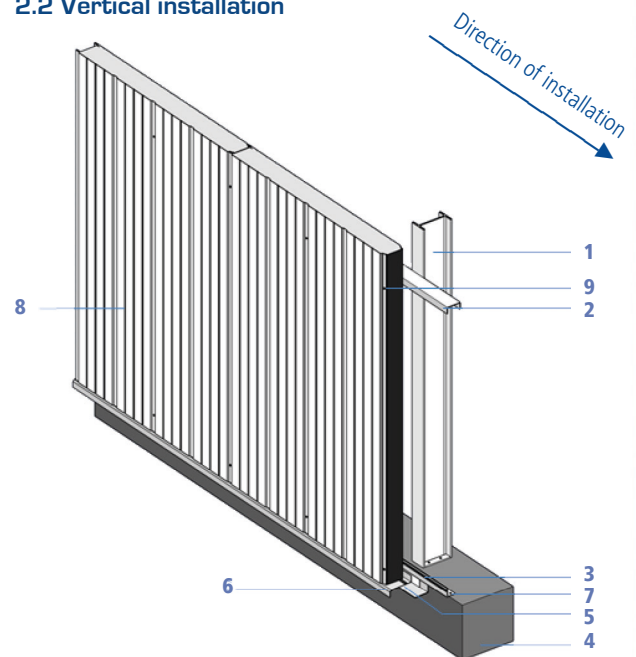

1. support structure, 2. bay rail 3. sealing tape, 4. base, 5. supporting profile, 6. dripping profile, 7. mounting angle, 8. sandwich panel Monowall, 9. fastener

minimum support width:

end bearing  $\geq 40$  mm

middle bearing  $\geq 60$  mm

joint area  $\geq 86$  mm (for horizontal installation, larger support widths may be necessary due to structural requirements)

### 3. Fixing

The necessary number of screws is defined by structural requirements (fastener supporting documents). Screws are to be drilled through from the external side directly into the support structure. Additional sealing of longitudinal joint or additional screwing of the joint itself is not necessary. Execute screw connection as uniform and consistent as possible. Construction-wise, all panels need to be fastened with at least two screws on both end- and middle bearing.

Internal side

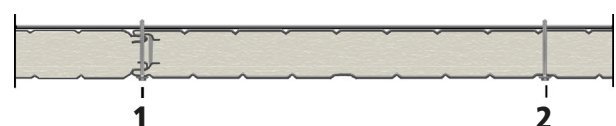

External side

1. fastening device through the closure  
2. centre fastening

## Sandwich panel wall

### Monowall installation manual

#### 4. Fixing material

For fastening sandwich panels, only fixing material with EPDM-gasket according German "bauaufsichtliche Zulassung Nr.14.4-407" or according European technical approval (ETA) must be used.

##### 4.1 Fixing on steel support structure

Minimum diameter for approved screws is generally 5,5mm (depending on supplier). The required screw length may vary depending on supplier and is defined by:

- thickness of the sandwich panel Monowall
- material strength of the support structure ( $t \geq 1,50 \text{ mm}$ )
- clamping width

The following table shows minimum screw lengths for the various core thicknesses of Monowall:

Type of fastener	self-drilling screw	thread-rolling screw
Panel thickness (mm)	(mm)	(mm)
40	$\geq 70$	$\geq 60$
50	$\geq 80$	$\geq 70$
60	$\geq 90$	$\geq 80$
80	$\geq 110$	$\geq 100$
100	$\geq 130$	$\geq 120$
120	$\geq 150$	$\geq 140$

Self-drilling screws must be drilled through the support structure. Additional instructions by screw-supplier need to be considered as well.

##### 4.2 Fixing on wooden support structure

Minimum diameter for approved screws is generally 6,0 mm (depending on supplier). The required screw length may vary depending on supplier and is defined by:

- thickness of the sandwich panel Monowall
- minimum screwed-in depth ( $l_{ef} \geq 50 \text{ mm}$ )
- clamping width

The following table shows minimum screw lengths for the various core thicknesses of Monowall:

Type of fastener	self-drilling screw	thread-rolling screw
Panel thickness (mm)	(mm)	(mm)
40	$\geq 100$	$\geq 60$
50	$\geq 110$	$\geq 70$
60	$\geq 120$	$\geq 80$
80	$\geq 140$	$\geq 100$
100	$\geq 160$	$\geq 120$
120	$\geq 180$	$\geq 140$

We recommend having the screws being checked and retightened (if needed) approximately 3 months after installation.

#### 5. Distance between fasteners

The distance between fasteners needs to be followed according to Z-10.49-516 resp. Z-10.4-583 as well as the minimum edge distances for wooden support structures according DIN EN 1995-1-1.

##### 5.1 Distances perpendicular towards clamping direction

Minimum distance for fasteners towards the longitudinal edges is 50mm; minimum distance of fasteners among each other is 100mm.

##### 5.2 Distances parallel towards clamping direction

Minimum distance for fasteners towards the cross edges of the wall panels is 20mm plus 3-times the screw diameter; minimum distance of fasteners among each other equals distance of support construction.

#### 6. Connections

##### 6.1 General notes

Connections of wall panels towards adjacent parts of the building need to be realized according Z-10.49-516 resp. Z-10.4-583, according Metecno-connection details as well as according IFBS-rules.

##### 6.2 Upper connections

The joint between wall-and roof panels is to be sealed against convection and diffusion with adequate flashings and sealing tapes. The remaining cavity is to be filled with polyurethane foam.

##### 6.3 Roof parapet

Minimum distance between sandwich panel and parapet-profile is 6mm. The parapet-flashing needs to have a minimum slope of 5°.

##### 6.4 Lower connections (base)

Wall panels need to be set onto a supporting profile to accomplish a horizontal edge along the building line. Panels must not be placed directly onto the base or dripping profile (use mounting aid, e.g. wooden ledge). We recommend a distance of 10mm, essentially 6mm at minimum. The dripping profile needs to have a minimum slope of 5° directed outwards. The dripping edge needs to have minimum distance of 20mm towards the underlying wall. Scarf joints need to be provided with an adequate flashing.

##### 6.5 Small openings

Pipe penetrations in the joint areas of the panel are to be avoided. Openings in wall panels smaller than 200mm x 200mm resp.  $\emptyset$  max. 200mm do not require additional support construction and may be realized with adequate sleeves (adapted to the profile geometry of the panel) with circular sealing. For openings in the joint area of the panel, the draining water needs to be dissipated securely outwards.

## Sandwich panel wall

### Monowall installation manual

on the external layer of the joint. Multiple small openings need to be aligned with minimum disturbance to the panel (e.g. parallel and perpendicular offset of the openings). Bigger openings require a supporting substructure along the edges, which both panel and adjacent building parts are fastened to.

#### 6.6 External corner flashings

Joints on external corners of the building need to be sealed adequately and covered with flashings.

#### 6.7 Longitudinal joint

To assure sufficient compression of the provided sealing tapes, the given building width of the panel needs to be maintained thoroughly. This should be done by check measurements every few meters (on the top and bottom for vertical installation; left and right for horizontal installation as well as above and below middle bearing). Protective foil is to be removed from the joints duly before fastening.

#### 6.8 Lateral joint

For lateral joints between two wall panels, a minimum supporting width of 86mm is required (joint min.6mm). Vertically installed wall panels require a butt connection in the lateral joint with a dripping profile in between. Joints need to be sealed with adequate sealant/sealing tapes.

Vertical pilaster strips allow versatile visual possibilities for horizontally installed wall panels. However, larger supporting widths may be necessary depending on the type of design.

Possible variants for covering of lateral joint:

##### 1. Flashing, e.g. hat-profile

- supporting width  $\geq$  100 mm

##### 2. Extruded aluminum sheath pilaster profile 130

- supporting width  $\geq$  130 mm

(see detail: lateral joint for horizontal installation of wall panels XX.08.02)